



96 x 96mm

### FEATURES

- 3Phase True RMS (Voltage, Current)
- 3Phase Power (Active, Reactive, Apparent),
- Energy (Active, Reactive, Apparent)
- Programmable CT, PT (Primary / Secondary)
- RS485 Communication MODBUS RTU Protocol
- % THD Upto 31<sup>st</sup> Harmonic

### Display Specifications

Type	: 3 rows, 7 Segment LED Display
Digits	: 4 Digit
Energy	: 8Digit for Energy display

### Input Specifications

Electrical Connection	: 3Phase-4Wire, 3Phase-3Wire, 1Phase-2Wire
Input Voltage Range	: 11 to 300V AC (L-N), 19 to 519V AC (L-L)
Input Current Range	: Nominal 5A AC (Min - 11mA, Max - 6A)
Frequency	: 45 to 65Hz
Display Scrolling	: Automatic / Manual / Default
Power Consumption	: 8VA max
Display Reset	: Programmable (For energy & Max demand)
Resolution	: For energy : 0.01k, 0.1k, 1k, 0.01M, 0.1M, 1M (depending Upon CT ratio x PT ratio) For Power, Voltage, Current : Auto Resolution For Power Factor : 0.001, Harmonics 0.1%
Accuracy	: Voltage (L-N / L-L) : $\pm 0.5\%$ of F.S. Current : $\pm 0.5\%$ of F.S. Power Factor : $\pm 1.0\%$ Frequency : $\pm 0.2\%$ Power (Active, Reactive, Apparent) : $\pm 1.0\%$ Energy (Active, Reactive, Apparent) : Class $\pm 1.0\%$
Memory Retention	: 10 years (For energy)
Measuring Parameters	: Voltage (L-L / L-N) (Individual / Average), Current (Individual / Average), Frequency, Power Factor (Individual / Total), Active, Reactive & Apparent Power (Individual / Total), Active, Reactive & Apparent Energy (Total) % THD upto 31 <sup>st</sup> Harmonic for Voltage & Current / Maximum (Rising) Demand, Auxillary interrupt, Phase Sequence Detection
DG Input	: 230V AC (For DG models only)

### Output Specifications

Communication Interface	: RS485 and MODBUS RTU and Protocol
Communication Address	: 1 to 255
Transmission Mode	: Half duplex
Transmission Distance	: 500 meter maximum
Transmission Speed	: 9600 (in bps)
Parity	: None, Odd, Even
Stop Bits	: 1 or 2
Response Time	: 100ms (max and independent of baud rate)

### Auxiliary Supply Specifications

Supply Voltage	: 85 to 270V AC/DC
----------------	--------------------

### Settable Parameters

CT Primary	: 5A to 5000A AC (Programmable for any value)
CT Secondary	: 5A or 1A AC (Factory Settable)
PT Primary	: 100V to 500kV AC (Programmable for any value)
PT Secondary	: 100V to 500V AC (L-L) (Programmable for any value)

### Environmental Specifications

Temperature	: Operating Temperature : $-10^{\circ}$ to $55^{\circ}\text{C}$ Storage Temperature : $-20^{\circ}$ to $75^{\circ}\text{C}$
Humidity	: Up to 85% RH

### Mechanical Specifications

Mounting	: Panel Mount
Size	: 96X96mm
Weight	: 230gms
Screw Tightening Torque	: 0.5 NM

### Mechanical Specifications

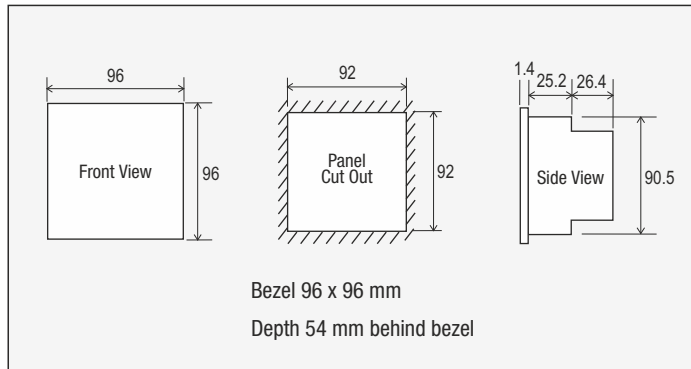

### Connection Diagram

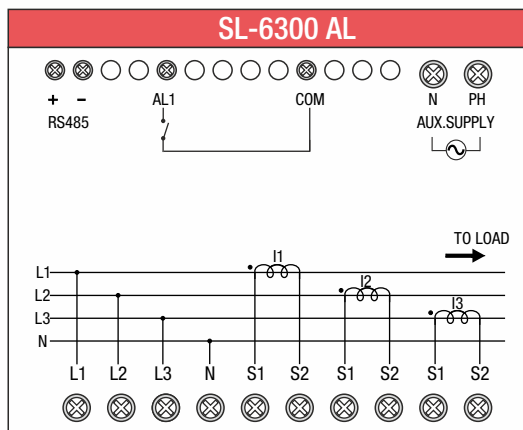
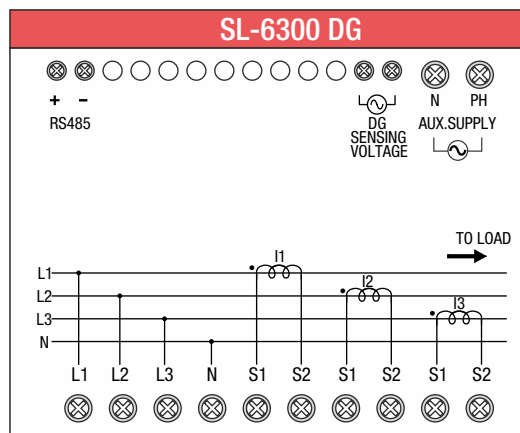
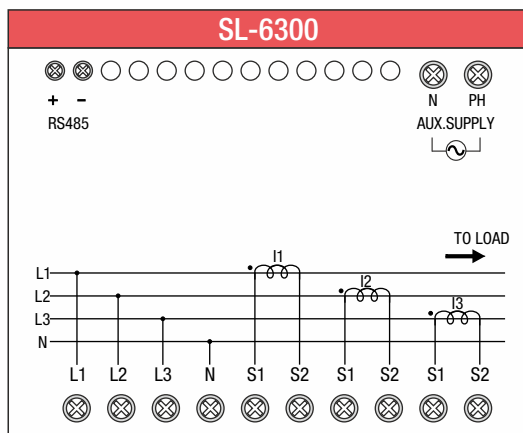

### Ordering Information

PRODUCT NAME	DESCRIPTIONS
SL6300-3PH	SMART LOAD MANAGER 3 PHASE 96X96
SL6300-3PH-RS	SMART LOAD MANAGER 3 PHASE 96X96 RS485
SL6300-3PH-DG	SMART LOAD MANAGER 3 PHASE 96X96 DG
SL6300-3PH-DG-RS	SMART LOAD MANAGER 3 PHASE 96X96 DG RS485
SL6300-3PH-AL	SMART LOAD MANAGER 3 PHASE 96X96 ALARM
SL6300-3PH-AL-RS	SMART LOAD MANAGER 3 PHASE 96X96 ALARM RS485
SL6300-3PH-RS-DG-AL	SMART LOAD MANAGER 3 PHASE 96X96 RS485-DG-ALARM